

# DLP Projector LX-MU700

## 1. Main Features

### 1-1. Dual-Lamp Installation Model with High Brightness of 7500 lm

The brightness of 7500 lm is attained by the dual lamps installed, and the projector is especially useful in a large auditorium.

Additionally, in case one of the lamps goes out, the projector will still be usable with the other lamp. (If the lamp blows out, maintenance by service personnel is required.)

Furthermore, projector can be used either in dual-lamp mode or in single-lamp mode. By switching between the two lamps, the projector can be used for a long time.

### 1-2. Two types of color wheels for different purposes

In addition to the color wheel with brightness prioritized initially included with the projector, the projector also includes a color wheel with color prioritized in its package.

### 1-3. Wide selection of interfaces

The projector is equipped with variety of input terminals including HDBaseT, DisplayPort, HDMI, DVI-D, and 5BNC.

Since the projector can be simultaneously connected to multiple input devices, a highly usable system can be configured.

### 1-4. 7 types of projection lenses

The projection lenses of this projector are interchangeable.

With a selection of 7 lenses from short-range to ultra-long range, wide range of projection distances (mounting positions) can be chosen.

This is to respond to users in various installation environments.

## 2. Specifications

### 2-1. Basic specifications

Mode		LX-MU700
Type	Product type	Projector
	Imaging device, number	DLP x1
DMD	Number of pixels	1920×1200 (WUXGA)
	Size, Aspect ratio	0.67 type, 16:10
Light source	Lamp type	Super-high pressure lamp for projectors x2
	Lamp power (*1)	350/280 W x2
Images	Optical system	Time division color extraction, sequential display (Color Wheel)
	Brightness (*2)	7500 lm (Dual-Lamp, Lamp mode: Normal)
	Marginal illumination ratio (*2)	85%
	Contrast ratio (*2)	2100:1
	Image size (*2)	50 – 300 inch (16:10)
	Amount of lens shift (*2)	V: 0% – 50%、H: ±10% (Powered)
	Electrical zoom (by length)	No
	Keystone correction range	V ±40°
Terminals	Dsub15 (COMPUTER-1)	Analog PC / Component video input
	5BNC (COMPUTER-2)	Analog PC / Component video input
	DVI-D	Digital PC/Digital video input
	HDMI	Digital PC/Digital video input
	DisplayPort	Digital PC/Digital video input
	RJ-45	HDBaseT input / Network connection (100BASE-TX / 10BASE-T)
	Dsub15(MONITOR-OUT)	Image output
	Dsub9 (CONTROL)	RS-232 connection
	USB mini B	Service port
	3D sync out	For 3D display
	Mini jack (TRIGGER)	For picture control
	Mini jack (REMOTE)	Wired remote control connection
Image signal	Analog PC input	WUXGA/WSXGA+/UXGA/SXGA+/WXGA+/WXGA/SXGA/XGA/SVGA/VGA
	Digital PC input	WUXGA/WSXGA+/UXGA/SXGA+/WXGA+/WXGA/SXGA/XGA/SVGA/VGA
	Digital video input	1080p/1080i/720p/576p/480p
	Component video input	1080p/1080i/720p/576p/480p/576i/480i
	HDBaseT	Same as Digital PC input/digital video input
Mechanics	Adjustable feet	Front: 2, Rear:1
	Built-in speaker	No
	Dimension	W: 504 mm, H: 529 mm, D: 221 mm W: 19.8 in, H: 20.8 in, D: 8.7 in
	Mass	20.5 kg
	Noise level (*1)	Dual-Lamp:41/36 dB, Single-Lamp:38/35dB
Others	Power supply	AC 100-240V, 50/60Hz
	Power consumption (*1)	Dual-Lamp:850/680 W, Single-Lamp:440/370 W
	Standby power consumption (*3)	6.0/0.5 W
	Operation environment	5°C - 40°C

\*1: Lamp mode is Normal/Eco

\*2: When using a Standard Zoom Lens (LX-IL03ST)

\*3: Standby mode is Network/Eco

## 2-2. Specification of projection lens (Option)

Projection lens	F number	Focal length	Zoom ratio	Image size	Throw ratio (*1)	Lens shift
LX-IL01UW	1.96-2.3	11.3-14.1 mm	1.25x	40-500 inch (*2)	0.75-0.93:1	V 0-50% H ± 6.7%
LX-IL02WZ	1.85-2.5	18.7-26.5 mm	1.41x	40-500 inch (*2)	1.25-1.79:1	V 0-50% H ± 10%
LX-IL03ST	1.7-1.9	26-34 mm	1.3x	40-500 inch (*2)	1.73-2.27:1	V 0-50% H ± 10%
LX-IL04MZ	1.86-2.48	32.9-54.2 mm	1.65x	40-500 inch (*2)	2.22-3.67:1	V 0-50% H ± 10%
LX-IL05LZ	1.85-2.41	52.8-79.1 mm	1.5x	40-500 inch (*2)	3.58-5.38:1	V 0-50% H ± 10%
LX-IL06UL	1.85-2.48	78.5-121.9 mm	1.55x	40-500 inch (*2)	5.31-8.26:1	V 0-50% H ± 10%
LX-IL07WF	1.85	11.6 mm	(Fixed)	40-500 inch (*2)	0.76:1	V 0% H 0%

\*1: Calculated value for 80-inch image

\*2: Indicates focus ability range in this chart. Optical feature guaranteed range is: 50-300 inches.

## 2-3. Installation Specifications

### ●Image Size and Projection distance

LX-MU700 is a projector with interchangeable lenses, and as of this writing (September 2015), 7 types of projection lenses are available.

Relationship between projection distance and picture is described below.

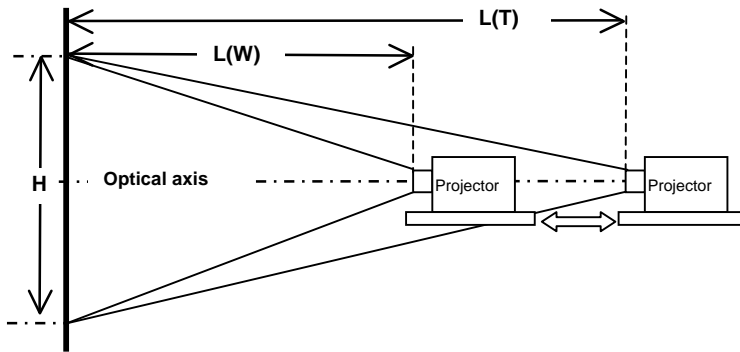

Picture of the height (H) is projected at between the shortest distance L(W) and L(T).

(W) denotes wide end, and (T) tele end. The lens shift ratio can be changed on this projector.

The figure left denotes an example of 1:1 ratio, and the picture is divided into two making the optical axis as its center.

The figure indicates a case where a zoomable projection lens is used.

For a projection lens with no optical zoom feature, the projection distance is indicated by L.

The relationship between picture size and projection distance varies according to the projection lens mounted.

The graph below denotes the projection distances for 100-inch image.

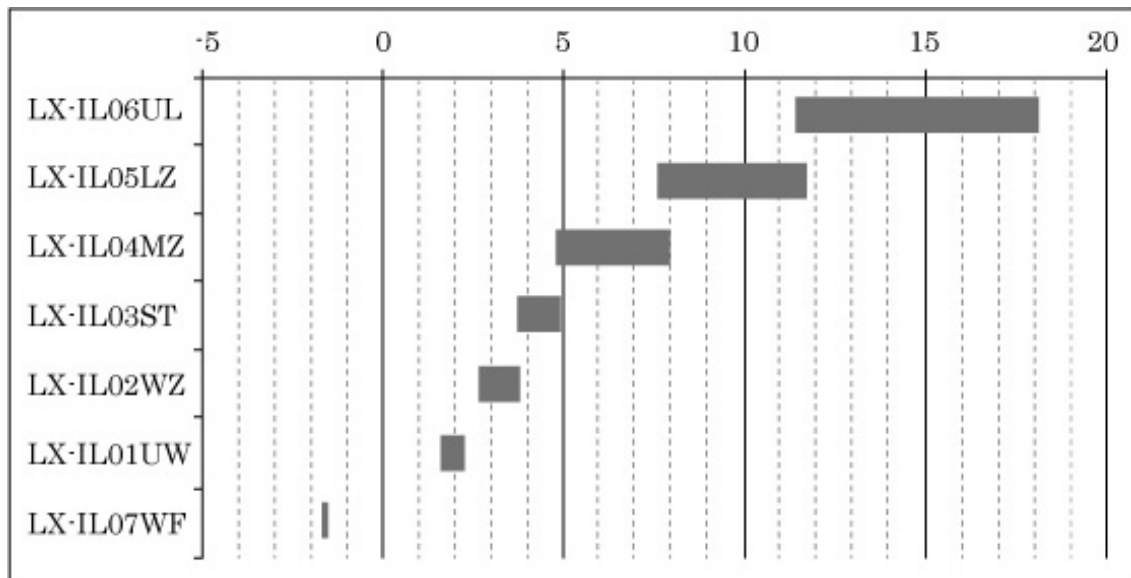

●Projection distance

Image size (16:10)			LX-IL01UW		LX-IL02WZ		LX-IL03ST		LX-IL04MZ	
Diagonal [type]	Width [cm]	Height [cm]	L(W) [cm]	L(T) [cm]	L(W) [cm]	L(T) [cm]	L(W) [cm]	L(T) [cm]	L(W) [cm]	L(T) [cm]
40	86	54	0.62	0.79	1.05	1.52	1.45	1.93	1.87	3.15
50	108	67	0.79	1	1.33	1.92	1.83	2.42	2.36	3.96
60	129	81	0.96	1.2	1.6	2.31	2.21	2.92	2.85	4.77
80	172	108	1.29	1.62	2.16	3.09	2.97	3.92	3.82	6.39
100	215	135	1.62	2.04	2.71	3.88	3.73	4.92	4.8	8
120	258	162	1.96	2.45	3.26	4.66	4.49	5.91	5.78	9.62
150	323	202	2.46	3.08	4.09	5.84	5.63	7.41	7.24	12.04
180	388	242	2.96	3.7	4.92	7.02	6.77	8.9	8.7	14.47
200	431	269	3.29	4.12	5.47	7.81	7.53	9.9	9.68	16.08
300	646	404	4.96	6.2	8.23	11.73	11.34	14.9	14.56	24.16
400	862	538	6.63	8.28	10.99	15.66	15.14	19.87	19.44	32.25
500	1077	673	8.3	10.36	13.75	19.59	18.94	24.85	24.32	40.33

Image size (16:10)			LX-IL05LZ		LX-IL06UL		LX-IL07WF
Diagonal [type]	Width [cm]	Height [cm]	L(W) [cm]	L(T) [cm]	L(W) [cm]	L(T) [cm]	L(W) [cm]
40	86	54	3.01	4.6	4.42	7.05	0.64
50	108	67	3.8	5.78	5.59	8.89	0.81
60	129	81	4.59	6.96	6.77	10.73	0.98
80	172	108	6.16	9.33	9.13	14.4	1.32
100	215	135	7.73	11.7	11.48	18.07	1.66
120	258	162	9.31	14.06	13.84	21.75	2.01
150	323	202	11.67	17.61	17.37	27.26	2.52
180	388	242	14.03	21.16	20.91	32.77	3.03
200	431	269	15.6	23.53	23.26	36.44	3.37
300	646	404	23.47	35.36	35.04	54.81	5.08
400	862	538	31.34	47.19	46.82	73.18	6.79
500	1077	673	39.21	59.02	58.6	91.54	8.5

\* The distances listed on the table have been rounded off and are therefore approximate values.

## 2-4. Adjustable foot

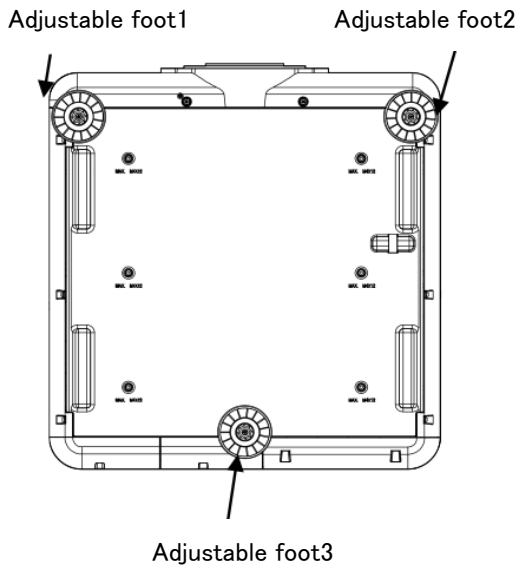

The figure on the left is a schematic diagram of the bottom of the projector.

As shown in the figure, there are three adjustable feet.

Adjusting the lengths of Adjustable feet 1 and 2 raises the projection direction while adjusting the length of Adjustable foot 3 lowers the projection direction.

Adjustable feet 1 and 2 can be used to make fine adjustments to the horizontal slant of the projector.

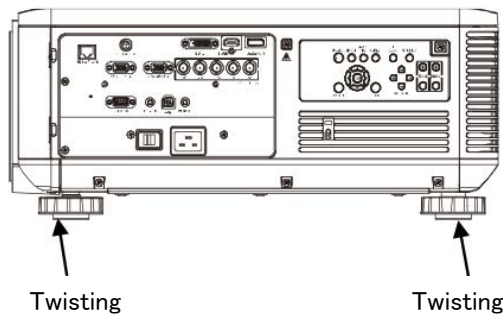

The figure on the left is a schematic diagram of the side of the projector.

All adjustable feet are a screw-type and their heights can be adjusted by twisting.

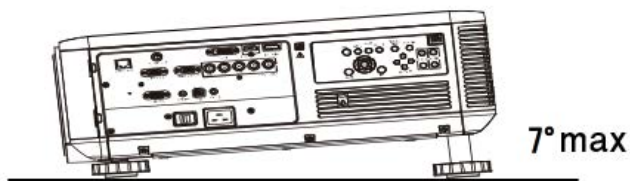

The projector can be set up at an angle of elevation of up to 7degrees between itself and the surface it is placed on.

\* The figure is for explanation only and different from the actual product shape.

### 3. Accessories

\*Only the items relevant to using the product have been extracted from a list of items.

Main Supplied Accessories	Remote control LX-RC01	Power supply: DC 3.0V (with 2 AA batteries ) Communication range: approx.10 m within ±30 degrees of the receiver
	Power Cord	Connects the unit to a power source.
	Computer cable	Mini Dsub15-Mini Dsub15 This is used for connection with computer. This transmits analog PC signals.
	Color Wheel	A replacement color wheel with different chromatic display characteristics than the original color wheel attached at factory setting. **Original Color Wheel: Brightness prioritized **Replacement Color Wheel: Hue prioritized
	Anti-theft screw for lens	M4 x 0.7 x 70 mm Used to prevent the mounted projection lens from easily being removed.
	Dust Cap	Prevents dust from entering the projector from the lens mount opening while no projection lens is mounted to the projector.
Optional Part	Remote control LX-RC01	Same as the supplied remote
	Ceiling Attachment (*1) RS-CL15	Used to suspend the projector from ceiling.
Replacement Parts	Lamp Assembly LX-LP01	Super-high pressure mercury lamp for projector Recommended lamp replacement time(*2) 2000H/3000H (Lamp mode: Normal / Eco)
	Air filter Assembly LX-FL01	Attached to air vent, prevents power dust, etc. from entering the projector.

\*1: Since the size and weight varies according to the projector, be sure to use the specified fittings.

Consult a professional for mounting position and installation.

\*2: This value indicates the time at which residual ration is at 50% and illuminance can be maintained at the ratio of 50%.

This value is not to be used to guarantee the operating life of lamps.

Projection lens	Ultra Wide Zoom Lens LX-IL01UW	Zoom ratio: 1.25x Projection distance: 11.3-14.1 mm F number: 1.96-2.3
	Wide Zoom Lens LX-IL02WZ	Zoom ratio: 1.41x Projection distance: 18.7-26.5mm F number: 1.85-2.5
	Standard Zoom Lens LX-IL03ST	Zoom ratio: 1.3x Projection distance: 26-34 mm F number: 1.7-1.9
	Medium Zoom Lens LX-IL04MZ	Zoom ratio: 1.65x Projection distance: 32.9-54.2 mm F number: 1.86-2.41
	Long Zoom Lens LX-IL05LZ	Zoom ratio: 1.5x Projection distance: 52.8-79.1 mm F number: 1.85-2.48
	Ultra Long Zoom Lens LX-IL06UL	Zoom ratio: 1.55x Projection distance: 78.5-121.9 mm F number: 1.85-2.48
	Short Fixed Lens LX-IL07WF	Zoom ratio: (No optical zoom) Projection distance: 11.6 mm F number: 1.85



## 4. Product Appearance

### ●Outline Drawings

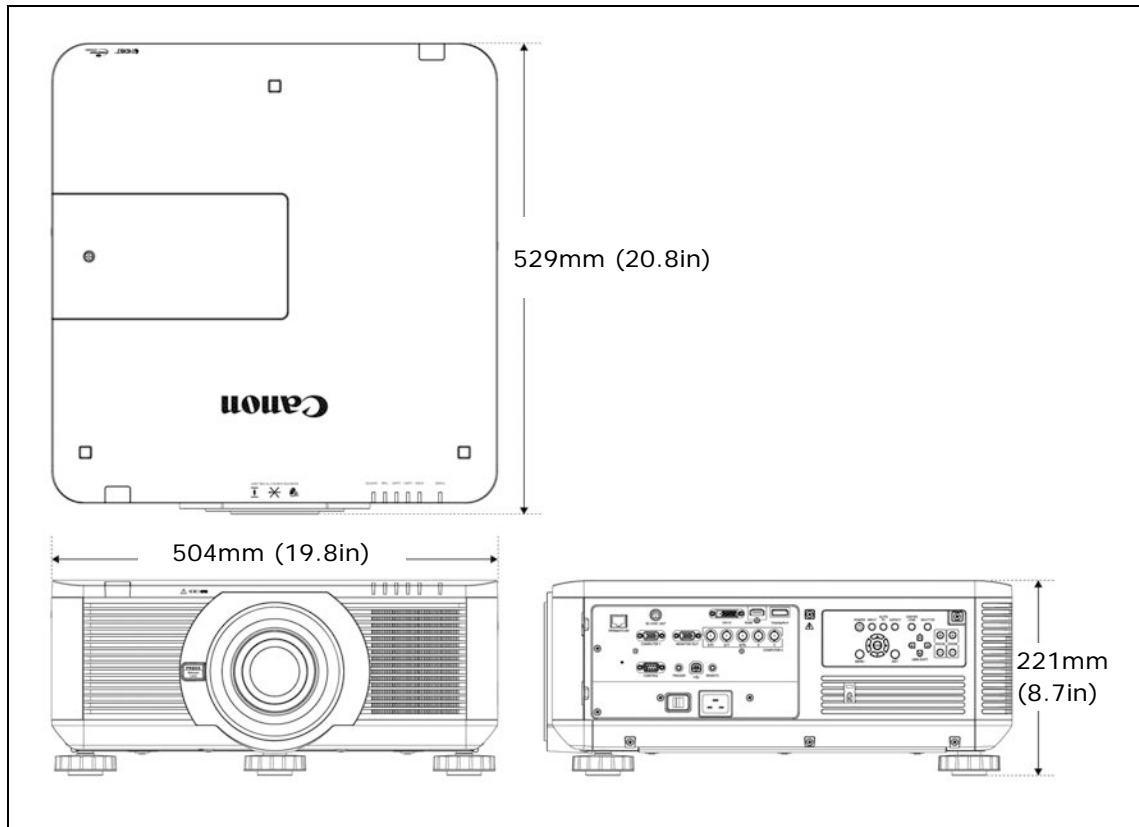

#### Dimensions

W: 504 mm, H: 221 mm, D: 529 mm (19.8 x 8.7 x 20.8 inch)

Mass: 20.5 kg (45.2 lbs)

## 5. Precautions For Use

- **Do not look into the projection lens while it is projecting.**

The projector emits very bright light, which may damage your vision.

- **Do not place objects in front of the lens while projecting.**

Objects may heat up and burn if exposed to the concentrated light of the projector for long periods.

- **Do not block the air vent while the projector is running.**

Allowing heat to build up inside the unit may lead to malfunctions or risk of fire.

- **Do not use the projector when tilted excessively.**

Place the projector on surfaces with a horizontal slant.

Due to the characteristics of the lamp, using the projector at an excessive inclination may cause the lamp to operate abnormally or shorten its service life.

This projector is not designed for horizontally slanted use. Keep the slant within 10 degrees.

- **Replace the lamp as soon as possible if the lamp burns out or if the replacement time is reached.**

The projector uses a high-pressure mercury lamp as its light source. This lamp degrades over time and becomes dimmer as it is used. Furthermore, the possibility of the lamp bursting as it is used is extremely high. If the lamp should burst, return the projector to your local service center to have the lamp replaced and the unit inspected.

\*\* The probability of occurrence of blowout of lamp before its replacement time is less than 50%; there is more chance that no blowout occurs till the end.

Even if it does blowout, the time until its occurrence varies by the unit.

While minor defects at manufacturing are suspected for the variations among the units, there is no way to predict the exact time before the blowout.

- **In highlands(\*1) with low atmospheric pressure, use with the following setting(\*1)**

Set the "High Altitude Mode" on.

\*1: 1500 m or more above sea level

- **For vertical projection, set the projection mode in "Adjust Menu" as follows.**

-Upward projection → "Upward + Front Projection"

-Downward projection → "Downward + Front Projection"