

LCOS 4K Projector 4K500ST

1. Main Features

1-1 Compact, lightweight, high luminance 5000 lm

A compact AISYS optical system that provides both brightness and contrast, an original high-performance image processor that achieves enhanced color reproduction, a high-definition projection lens that is a compilation of optical design technologies for unleashing the full potential of 4K resolution, and a 4K LCOS panel that can project smooth high-quality images were integrated to realize a 5000 lumen high-luminance 4K model with industry leading compactness and lightweight.

1-2 Two high-performance image processors

This product uses two Canon's proprietary image processors to support 4K image processing. They provide various functions as well as reproduce high-quality, true-to-life 4K images.

1-3 Newly developed 4K wide zoom lens

In addition to supporting 4K high definition, the projection lens of this product is designed with a throw ratio between 1.0 and 1.3, which is wider than typical standard projection lenses. This feature can meet customer needs in the simulation market and the like.

Further, the lens is designed so that the f-number is F2.6 over the entire zoom region. As such, the variation in brightness due to zoom control is suppressed to minimum.

1-4 0.76 inch 4K-LCOS panel (4096×2400 pixels), three LCOS panel projector

Three world's smallest class 4K-LCOS panels are integrated for high-speed and high-resolution control. High quality images that fully reflect the smooth LCOS characteristics are produced.

1-5 High-definition edge blending technologies

The product contains technologies that make edge blending projection, a way of connecting multiple images, more beautiful.

- 1) Low distortion projection lens with no more than 0.12% TV distortion.
- 2) Sub pixel correction that electrically corrects color displacement in unit of 0.1 pixels in a specific area of the screen.

1-6 Curved surface projection technologies

The product includes technologies for projecting images beautifully onto a dome-shaped screen and the like.

- 1) Supports curved surface screens with a periphery focus adjustment function that corrects the curvature of the image field and an optical correction function that is separate from the general focus drive.
- 2) Ensures field of depth with a large f-number (F2.6) projection lens and provides beautiful projection onto a curved surface as the f-number can be increased with the variable aperture arranged inside the illumination optical system.

1-7 Optimal movie performance for simulation applications

In order to accommodate simulation applications, this product includes technologies for producing 4K movies in real time with low level of motion blurring.

- 1) Low-delay playback that suppresses the delay from input to display to about 1.0 frame (at 60 Hz) (*3)
- 2) Employs a new system for movie visibility improvement (MB reduction) to display smoother movies than before.

1-8 HDMI input x 2, DVI input x 4

The product has two HDMI connectors and four DVI connectors for receiving 4K contents.

4K image input is made possible by using multiple input connectors. (*4)

In addition, this product supports dual link DVI input. (*5)

The product is able to receive and display image signals with large amount of information that could not be possible previously with single link support.

*1: The function that is displayed as "Advanced registration" on the menu screen

*2: Adjustable for 9x6 points.

*3: Keystone and other scaling functions are off. The image input is DVI 1x4 or HDMI 1x2.

*4: Some 4K images can be input through a single HDMI connector (e.g., 3840x2160, 30 Hz).

*5: Dual link mode refers to the use of two TMDS links on the DVI interface. It is used such as when the resolution or frequency is high. For signal transmission, connectors and cable with dual link construction are required.

2. Specifications

2-1 Basic specifications

Model		4K500ST
1) Type	Product type	Projector
	Imaging device, number	Reflective LCD panel (LCOS) ×3
2) LCOS panel	Number of pixels	4096×2400
	Size, Aspect ratio	0.76 inch, 128:75 (about 17:10)
	Driving system	Active Matrix
3) Projection lens	Lens configuration	12 groups 16 elements
	F number, Focal length	F2.6, f=17.2 – 22.3 mm
	Zoom magnification	1.3 times
	Projection distance	0.9 – 17.7 m
	Distance for 100 “ image	2.2 – 2.9 m
	Throw ratio (*1)	1.0:1 - 1.3:1
	Operation	Zoom: powered, Focus: powered, Lens shift: Powered Marginal focus: powered
4) Light source	Type	Super High Pressure Lamp for projectors
	Power (*2)	400/300 W
5) Images	Optical system	Dichroic mirror and PBS color separation-combination system
	Brightness (*2)	5000/3750 lm
	Marginal lumination ratio	88%
	Contrast ratio	2500:1 (Native)
	Image size (4096 x 2400)	40 – 600 inches
	Lens shift	V: ± 60%, H: ±10%
	Electronic zoom (for length)	Not provided
	Keystone correction	V ±20°, H ±20°
6) Terminals	DVI-D x4	Digital PC input
	HDMI x2	Digital PC/Digital video input
	Mini jack x2	Audio input x1, Audio output x1
	Mini jack x1	Wired remote control connection
	Dsub9	RS-232C connection
	USB Type A	USB connection
	RJ-45	Network connection (1000BASE-T / 100BASE-TX / 10BASE-T)
6) Image signals	DVI (single)	640x480, 800x600, 1280x720, 1024x768, 1366x768, 1440x900, 1280x1024, 1920x1080, 2048x1080, 2560x1080, 1920x1200, 2048x1200, 2560x1440, 3840x2160(*3), 4096x2160(*3)(*4)
	DVI 1x2	2560x1080, 2560x1440, 2560x1600, 3840x2160(*3), 4096x2160(*3)
	DVI 2x2	3840x2160, 4096x2160, 4096x2304(*5), 3200x2400(*5), 3840x2400(*5), 4096x2400(*5)
	DVI 1x4	3840x2160, 4096x2160, 4096x2304(*5), 3840x2400(*5), 4096x2400(*5)
	HDMI (single)	640x480, 720x480, 720x576, 800x600, 1280x720, 1024x768, 1366x768, 1440x900, 1280x1024, 1920x1080, 2048x1080, 2560x1080, 1920x1200, 2048x1200, 2560x1440, 2560x1600, 3840x2160(*3), 4096x2160(*3)
	HDMI 1x2	1280x480, 1440x480, 1440x576, 2560x720, 3840x1080, 2560x1600, 3840x2160, 4096x2160, 3200x2400(*5), 3840x2400(*4)(*5)
8) Mechanics	Adjustable feet	Four locations on the bottom, Extension length: 12 mm
	Built-in speaker	5 W 、 Monaural
	Dimensions	W: 470 mm, H: 175 mm, D: 533.5 mm
	Weight	17.6 kg
	Noise level (*2)	39/34 dB
9) Others	Power supply	AC100 - 240 V : 50/60 Hz
	Power consumption (*2)	600/470 W
	Stand-by power consumption (*3)	0.8/0.4 W
	Operation environment	0□ – 40□ , 20%RH – 85%RH
	Storage environment	-10□ – 60□

*1: Calculated value for 70” image

*2: Lamp mode is Full power/Power saver. Brightness in Power saver mode is only a calculated value, and is not guaranteed as specification

*3: Only low frequencies (24 to 30 Hz) are supported.

*4: EDID is not supported.

*5: Supported when “Panel drive mode” is set to “4096x2400”

*6: Network “ON” (Low-power) / “OFF”

2-2 Image size and projection distance

This product is suited to project pictures in maximum size of 600 inches.
 Projection distance to the corresponding picture size is as follows.
 Note that zoom and focus operations on this product is powered.

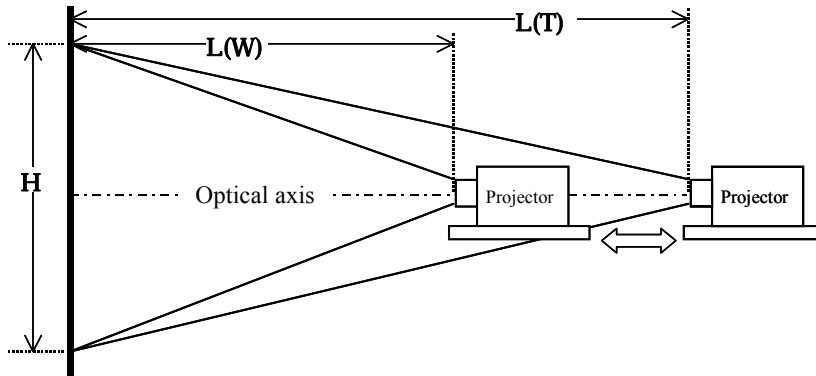

Image of height H is projected in the range from the shortest distance L (W) to the longest distance L (T).

(W) means the wide end and (T) means the tele end.

This product allows the lens shift ratio to be varied.

The left figure shows an example of 1:1 and image is divided with the optical axis at the center.

4K500ST

Image size (4096x2400)			Projection distance [m]	
[inches]	Width [m]	Height [m]	L(W)	L(T)
40	0.9	0.5	0.9	1.1
60	1.3	0.8	1.3	1.7
80	1.8	1.0	1.8	2.3
100	2.2	1.3	2.2	2.9
120	2.6	1.5	2.7	3.5
140	3.1	1.8	3.1	4.1
160	3.5	2.1	3.6	4.7
180	3.9	2.3	4.0	5.3
200	4.4	2.6	4.5	5.8
220	4.8	2.8	4.9	6.4
240	5.3	3.1	5.4	7.0
260	5.7	3.3	5.9	7.6
280	6.1	3.6	6.3	8.2
300	6.6	3.9	6.8	8.8
350	7.7	4.5	7.9	10.3
400	8.8	5.1	9.0	11.8
450	9.9	5.8	10.2	13.2
500	11.0	6.4	11.3	14.7
550	12.1	7.1	12.4	16.2
600	13.2	7.7	13.6	17.7

The distances listed on the table have been rounded off and are therefore approximate values.

2-3 Lens shift function and image position

This product has a lens shift function that can move the image position vertically and horizontally. The followings are the lens shift specifications of the 4K500ST.

Model	4K500ST
Amount of Lens shift	(V) -60% ~ 60% (H) -10% ~ 10%
Lens shift ratio	(V) -1:11 ~ 11:-1 (H) 4:6 ~ 6:4

The following figure shows the area in which the image can be moved and the guaranteed optical performance range of this product.

The center of the crosshair is the optical axis of the lens.

The octagonal area excluding the four corners (light gray) is the guaranteed optical performance range. Note that the sizes of the four corners that are outside the guaranteed range are the same.

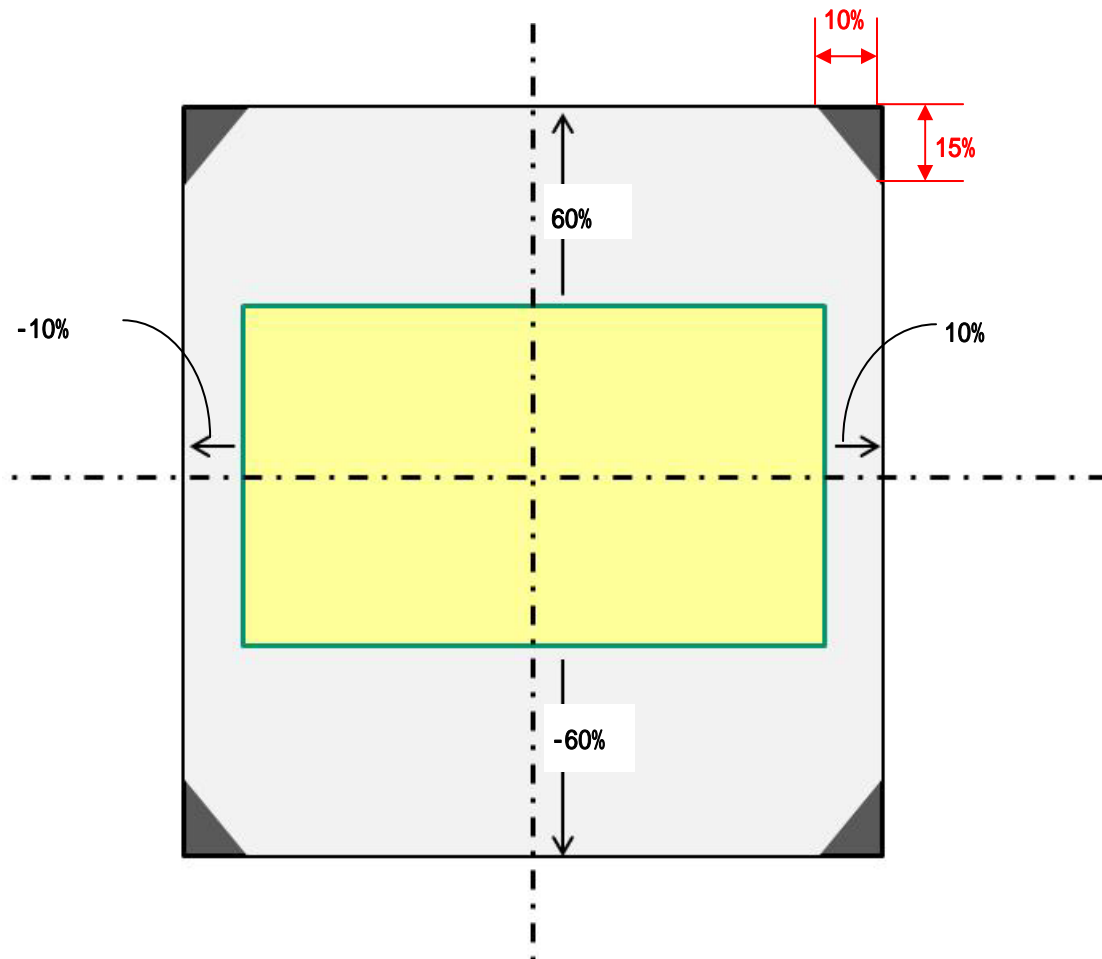

Moving the image outside the guaranteed optical performance range may cause shade to appear in the corner area of the image. (e.g., 60% vertical, 10% horizontal → the upper right corner of the image becomes dark)

We recommend that you do not use the product in this manner but rather adjust the installation position so that the image is within the guaranteed range.

2-4 Adjustable feet

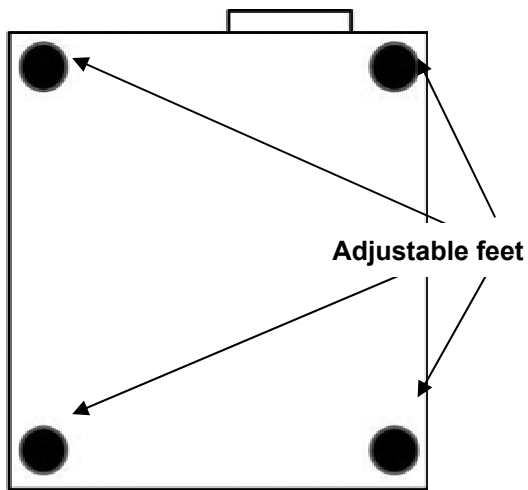

Four adjustable feet are provided on the bottom of the product.

The length of these feet can be adjusted to minimize the horizontal tilt of the image projected on the screen.

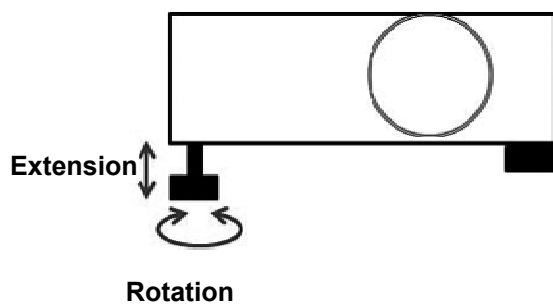

Rotate the adjustable legs to adjust their lengths.

The maximum extension length of each leg is 12 mm.

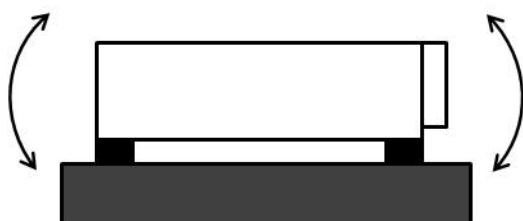

The front-to-back angle of this product can be adjusted in the range of ± 1.5 relative to the surface that the product is placed on.

* The figure is for explanation only and different from the actual product shape.

2-5 Notes on installation

Because this product uses a wide-angle lens, the following phenomenon may occur, but this is not a malfunction and poses no practical problems.

- **Image coloring**

When the image is viewed at an angle of 60 degrees or more from the front, a portion of the image appears colored.

If viewed from the left, the left side of the image appears colored in magenta. If viewed from the right, the right side of the image appears in the same way.

Likewise, if viewed from a vertical angle, the top or bottom side appears colored in green.

This is particularly evident in whitish images.

This phenomenon occurs as a result of polarization properties but may not be noticeable depending on the screen type.

The following figure shows an example when the image is viewed from the sides.

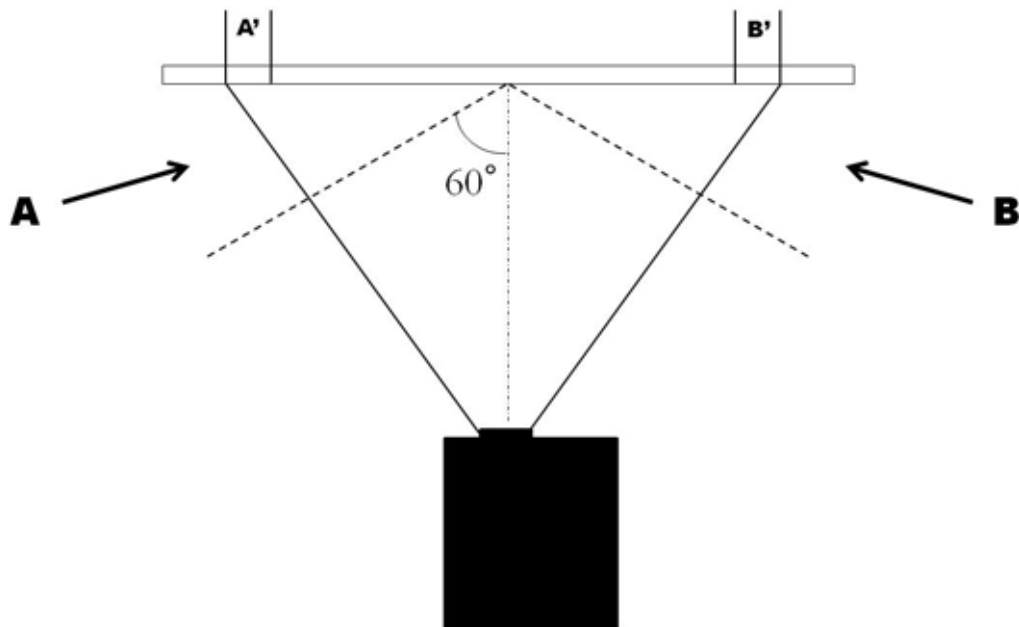

If viewed from direct A, area A' appears colored in magenta.

If viewed from direct B, area B' appears colored in magenta.

3. Image signals

3-1 Number of terminals used for image input

This product is equipped with a system that transmits image signals through several transmission cables to display high resolution image signals that could not be transmitted previously with a single transmission cable (DVI, HDMI).

The different combinations of image input terminals that the product uses are shown below.

Single terminal input (DVI1, DVI2, DVI3, DVI4, HDMI1, HDMI2)

The conventional method of transmitting image signals using a single transmission cable.

The screen of the output equipment is played back as is.

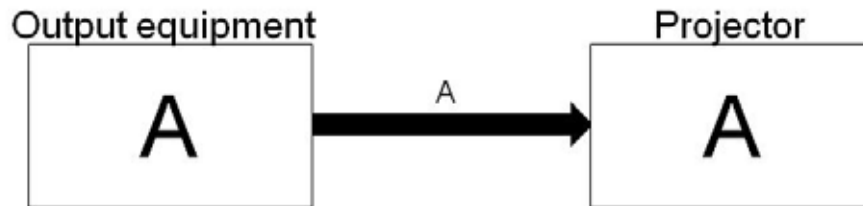

Two terminal input (DVI1+DVI3, HDMI1+HDMI2)

A method of transmitting image signals using two transmission cables.

For example, when transmitting a 3840x2160 image, each cable carries a 1920x2160 signal.

Image signals are divided into two signals, transmitted, composed, and played back.

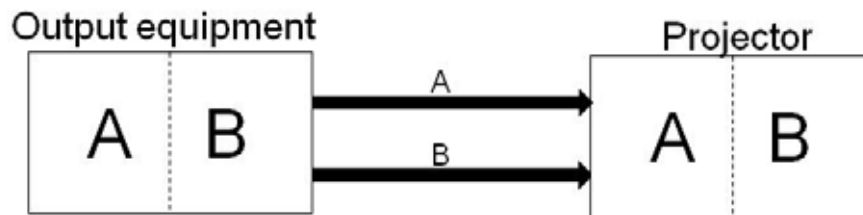

For DVI, signal A is received through DVI1 and signal B through DVI3.

For HDMI, signal A is received through HDMI1 and signal B through HDMI2.

Four terminal input, quadrant (DVI 2x2)

One of the methods of transmitting image signals using four transmission cables.

For example, when transmitting a 3840x2160 image, each cable carries a 1920x1080 signal.

Image signals are divided into quadrants, transmitted, composed, and played back.

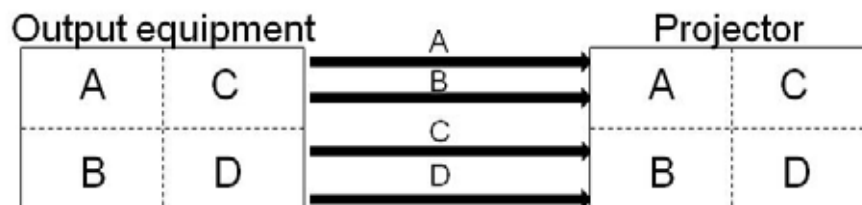

Signal A is received through DVI1, signal B through DVI2, signal C through DVI3, and signal D through DVI4.

Four terminal input, side by side (DVI 1x4)

One of the methods of transmitting image signals using four transmission cables.

For example, when transmitting a 3840x2160 image, each cable carries a 960x2160 signal.

Image signals are divided horizontally into four parts, transmitted, composed, and played back.

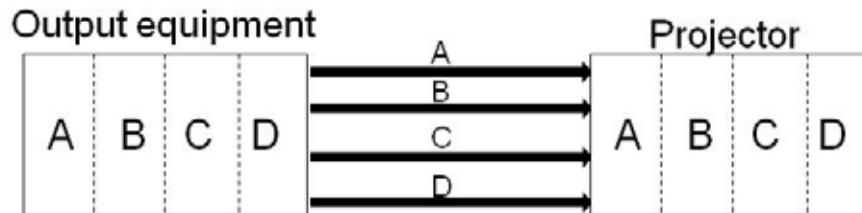

Signal A is received through DVI1, signal B through DVI2, signal C through DVI3, and signal D through DVI4.

Notes for receiving signals through multiple terminals

In order to reproduce images correctly when an image signal is divided and received through multiple terminals, the following items must at least be the same for each of the divided image signals.

- Period
- Resolution, frequency
- Color format

These are typically the same because it is assumed that images from a single output device will be divided and output. However, this may not be true depending on the specifications of the output device.

3-2 About Multi input mode select

On this product, EDID (a list of resolutions that can be received) is selected using “Multi input mode select”. (The EDID is selected separately for DVI and HDMI.) (*1)

If set to “Normal” the EDID will be a list containing a portion of the image signals that use a single terminal and a portion of the image signals that use several terminals.

With this setting, image signals with different numbers of terminals can be selected on the image output equipment side and output.

However, because not all image signals can be accommodated, if a setting is not in the list, the following menu is used to select a setting with a specific number of terminals.

Install settings Professional settings Multi input mode select

Here, the DVI or HDMI setting is changed from Standard to the number of terminals to be used (Single, 1x2, 2x2, or 1x4).

*1: EDID are different between panel drive mode settings

3-3 Supported image signal type

Image signals that the product can display are listed below.

The description of blanking information is provided later.

Interlace signals are denoted with (I).

For DVI input, a signal whose dot clock is less than 165 MHz is a single link signal, and that whose dot clock is 165 MHz or higher is a dual link signal.

●DVI (single)

Resolution	Frequency			Setting (*1)		Blanking information	
	Horizontal [kHz]	Vertical [Hz]	Dot clock [MHz]	Normal	Single	Horizontal FP, SW, BP	Vertical FP, SW, BP
640x480	31.469	59.940	25.175			16, 96, 48	10, 2, 33
800x600	37.879	60.317	40.000			40, 128, 88	1, 4, 23
1280x720	45.000	60.000	74.250			110, 40, 220	5, 5, 20
1024x768	48.363	60.004	65.000			24, 136, 160	3, 6, 29
1366x768	47.712	59.790	85.500	-		70, 143, 213	3, 3, 24
	48.000	60.000	72.000	(*2)		14, 56, 64	1, 3, 28
1440x900	55.935	59.887	106.500			80, 152, 232	3, 6, 25
	55.469	59.901	88.750			48, 32, 80	3, 6, 17
1280x1024	63.981	60.020	108.000			48, 112, 248	1, 3, 38
1920x1080	27.000	24.000	74.250			638, 44, 148	4, 5, 36
	67.500	60.000	148.500			88, 44, 148	4, 5, 36
2048x1080	66.576	59.924	147.000	(*2)		48, 32, 80	3, 10, 18
	67.500	60.000	148.500			44, 44, 64	4, 5, 36
2560x1080	66.636	59.978	181.250	(*2)		48, 32, 80	3, 10, 18
	66.000	60.000	198.000	-		248, 44, 148	4, 5, 11
1920x1200	74.556	59.885	193.250			136, 200, 336	3, 6, 36
	74.038	59.950	154.000			48, 32, 80	3, 6, 26
2048x1200	74.049	59.959	163.500			48, 32, 80	3, 10, 22
2560x1440	88.787	59.951	241.500	-		48, 32, 80	3, 5, 33
3840x2160	52.438	23.999	209.750	-		48, 32, 80	3, 5, 17
4096x2160	52.397	23.980	223.000	(*2)		48, 32, 80	3, 10, 12

●DVI 1x2

Resolution		Frequency			Setting (*1)		Blanking information	
Composed	Divided	Horizontal [kHz]	Vertical [Hz]	Dot clock [MHz]	Normal	1x2	Horizontal FP, SW, BP	Vertical FP, SW, BP
2560x1080	1280x1080	66.493	59.850	95.750	-		48, 32, 80	3, 10, 18
2560x1440	1280x1440	88.715	59.902	127.750	-		48, 32, 80	3, 10, 28
2560x1600	1280x1600	98.611	59.910	142.000			48, 32, 80	3, 10, 33
3840x2160	1920x2160	52.512	23.956	132.750	(*2)		104, 200, 304	3, 10, 19
		52.404	23.983	109.000	(*2)		48, 32, 80	3, 10, 12
		54.000	24.000	148.500	(*3)		638, 44, 148	8, 10, 72
4096x2160	2048x2160	52.515	23.957	142.000	(*2)		112, 216, 328	3, 10, 19
		52.423	23.992	115.750	(*2)		48, 32, 80	3, 10, 12
		54.000	24.000	148.500	(*3)		510, 44, 148	8, 10, 72

*1: Indicates multi input mode settings that allow image signal to be used

*2: Since EDID is not supported, the setting has no effect (standard recommended).

*3: Only when the "Panel drive mode" is set to "4096x2160"

•DVI 2x2

Resolution		Frequency			Setting (*1)		Blanking information	
Composed	Divided	Horizontal [kHz]	Vertical [Hz]	Dot clock [MHz]	Normal	2x2	Horizontal FP, SW, BP	Vertical FP, SW, BP
3840x2160	1920x1080	27.000	24.000	74.250			638, 44, 148	4, 5, 36
		66.587	59.934	138.500			48, 32, 80	3, 5, 23
		67.158	59.963	173.000			128, 200, 328	3, 5, 32
		67.500	60.000	148.500			88, 44, 148	4, 5, 36
4096x2160	2048x1080	66.576	59.924	147.000	-		48, 32, 80	3, 10, 18
		67.160	59.964	183.750	(*2)		128, 216, 344	3, 10, 27
		67.500	60.000	148.500			44, 44, 64	4, 5, 36
4096x2304 (*5)	2048x1152	71.584	59.903	197.000	(*4)	(*4)	136, 216, 352	3, 5, 35
		70.992	59.909	156.750	(*4)	(*4)	48, 32, 80	3, 5, 25
		72.000	60.000	162.000	(*4)	(*4)	26, 80, 96	1, 3, 44
3200x2400 (*5)	1600x1200	74.006	59.924	130.250	-	(*4)	48, 32, 80	3, 4, 28
		75.000	60.000	162.000	-	(*4)	64, 192, 304	1, 3, 46
		74.556	59.885	193.250		(*4)	136, 200, 336	3, 6, 36
		74.038	59.950	154.000		(*4)	48, 32, 80	3, 6, 26
4096x2400 (*5)	2048x1200	74.582	59.905	205.250	(*2)		136, 216, 352	3, 10, 32
		74.049	59.959	163.500		(*4)	48, 32, 80	3, 10, 22

•DVI 1x4

Resolution		Frequency			Setting (*1)		Blanking information	
Composed	Divided	Horizontal [kHz]	Vertical [Hz]	Dot clock [MHz]	Normal	1x4	Horizontal FP, SW, BP	Vertical FP, SW, BP
3840x2160	960x2160	134.036	59.918	178.000	(*2)		80, 104, 184	3, 10, 64
		133.259	59.973	149.250	-	(*3)	48, 32, 80	3, 10, 49
		133.319	60.000	138.652	(*2)		8, 32, 40	48, 8, 6
		135.000	60.000	148.500			44, 22, 74	8, 10, 72
4096x2160	1024x2160	134.055	59.926	188.750	(*2)		80, 112, 192	3, 10, 64
		133.235	59.962	157.750	-	(*3)	48, 32, 80	3, 10, 49
		133.320	60.000	147.185	(*2)		8, 32, 40	48, 8, 6
		135.000	60.000	148.500			22, 22, 32	8, 10, 72
4096x2304 (*5)	1024x2304	142.103	59.959	168.250	-	(*4)	48, 32, 80	3, 10, 53
		143.111	59.979	201.500	(*2)		80, 112, 192	3, 10, 69
		142.199	60.000	156.988	-	(*4)	8, 32, 40	52, 8, 6
3840x2400 (*5)	960x2400	147.991	59.940	165.750	-	(*4)	48, 32, 80	3, 10, 56
		149.096	59.974	198.000	(*2)		80, 104, 184	3, 10, 73
		148.139	60.000	154.065	(*4)	(*4)	8, 32, 40	55, 8, 6
4096x2400 (*5)	1024x2400	148.970	59.924	209.750	(*2)		80, 112, 192	3, 10, 73
		148.015	59.949	175.250	-	(*4)	48, 32, 80	3, 10, 56
		148.139	60.000	163.546	(*4)	(*4)	8, 32, 40	55, 8, 6

*1: Indicates multi input mode settings that allow image signal to be used

*2: Since EDID is not supported, the setting has no effect (standard recommended).

*3: Only when the "Panel drive mode" is set to "4096x2160"

*4: Only when the "Panel drive mode" is set to "4096x2400"

*5: In the case of an image signal whose vertical resolution exceeds 2160, if the panel drive mode is set to "4096x2160", it will be processed as "no signal." Therefore, set the mode to "4096x2400."

●HDMI (single)

Resolution	Frequency			Setting (*1)		Blanking information	
	Horizontal [kHz]	Vertical [Hz]	Dot clock [MHz]	Normal	Single	Horizontal FP, SW, BP	Vertical FP, SW, BP
640x480	31.469	59.940	25.175			16, 96, 48	10, 2, 33
720x480	31.469	59.940	27.000			16, 62, 60	9, 6, 30
720x576	31.250	50.000	27.000			12, 64, 68	5, 5, 39
800x600	37.879	60.317	40.000			40, 128, 88	1, 4, 23
1280x720	18.000	24.000	59.400			1760, 40, 220	5, 5, 20
	37.500	50.000	74.250			440, 40, 220	5, 5, 20
	45.000	60.000	74.250			110, 40, 220	5, 5, 20
1024x768	48.363	60.004	65.000			24, 136, 160	3, 6, 29
1366x768	47.712	59.790	85.500	-		70, 143, 213	3, 3, 24
	48.000	60.000	72.000	(*2)		14, 56, 64	1, 3, 28
1440x900	55.935	59.887	106.500			80, 152, 232	3, 6, 25
	55.469	59.901	88.750			48, 32, 80	3, 6, 17
1280x1024	63.981	60.020	108.000			48, 112, 248	1, 3, 38
1920x1080(I)	28.125	50.000	74.250			528, 44, 148	4.5, 10, 30.5
	31.250	50.000	72.000	(*2)		32, 168, 184	45.5, 10, 114.5
	33.750	60.000	74.250			88, 44, 148	4.5, 10, 30.5
1920x1080	27.000	24.000	74.250			638, 44, 148	4, 5, 36
	56.250	50.000	148.500			528, 44, 148	4, 5, 36
	67.500	60.000	148.500			88, 44, 148	4, 5, 36
2048x1080	66.576	59.924	147.000			48, 32, 80	3, 10, 18
	67.500	60.000	148.500			44, 44, 64	4, 5, 36
2560x1080	26.400	24.000	99.000			998, 44, 148	4, 5, 11
	56.250	50.000	185.625			548, 44, 148	4, 5, 36
	66.636	59.978	181.250	(*2)		48, 32, 80	3, 10, 18
	66.000	60.000	198.000			248, 44, 148	4, 5, 11
1920x1200	74.556	59.885	193.250			136, 200, 336	3, 6, 36
	74.038	59.950	154.000			48, 32, 80	3, 6, 26
2048x1200	74.049	59.959	163.500			48, 32, 80	3, 10, 22
2560x1440	88.787	59.951	241.500	-		48, 32, 80	3, 5, 33
	98.713	59.972	268.500			48, 32, 80	3, 6, 37
3840x2160	52.593	23.993	266.750	(*2)		216, 400, 616	3, 5, 24
	52.438	23.999	209.750	(*2)		48, 32, 80	3, 5, 17
	54.000	24.000	297.000			1276, 88, 296	8, 10, 72
	56.250	25.000	297.000			1056, 88, 296	8, 10, 72
	67.500	30.000	297.000			176, 88, 296	8, 10, 72
4096x2160	52.561	23.979	284.250	(*2)		224, 432, 656	3, 10, 19
	52.397	23.980	223.000	(*2)		48, 32, 80	3, 10, 12
	54.000	24.000	297.000			1020, 88, 296	8, 10, 72

*1: Indicates multi input mode settings that allow image signal to be used

*2: Since EDID is not supported, the setting has no effect (standard recommended).

*3: Only when the "Panel drive mode" is set to "4096x2160"

*4: Only when the "Panel drive mode" is set to "4096x2400"

●HDMI 1x2

Resolution		Frequency			Setting (*1)		Blanking information	
Composed	Divided	Horizontal [kHz]	Vertical [Hz]	Dot clock [MHz]	Normal	1x2	Horizontal FP, SW, BP	Vertical FP, SW, BP
1280x480	640x480	31.469	59.940	25.175			16, 96, 48	10, 2, 33
1440x480	720x480	31.469	59.940	27.000			16, 62, 60	9, 6, 30
1440x576	720x576	31.250	50.000	27.000			12, 64, 68	5, 5, 39
2560x720	1280x720	37.500	50.000	74.250			440, 40, 220	5, 5, 20
		45.000	60.000	74.250			110, 40, 220	5, 5, 20
3840x1080 (1)	1920x1080 (1)	28.125	50.000	74.250			528, 44, 148	4.5, 10, 30.5
		33.750	60.000	74.250			88, 44, 148	4.5, 10, 30.5
3840x1080	1920x1080	67.500	60.000	148.500			88, 44, 148	4, 5, 36
2560x1600	1280x1600	98.611	59.910	142.000	-		48, 32, 80	3, 10, 33
3840x2160	1920x2160	52.512	23.956	132.750	(*2)		104, 200, 304	3, 10, 19
		52.404	23.983	109.000	(*2)		48, 32, 80	3, 10, 12
		54.000	24.000	148.500	-	(*3)	638, 44, 148	8, 10, 72
		112.500	50.000	297.000	-		528, 44, 148	8, 10, 72
		133.293	59.988	277.250	(*2)		48, 32, 80	3, 10, 49
		135.000	60.000	297.000			88, 44, 148	8, 10, 72
		133.320	60.000	266.640	(*2)		8, 32, 40	48, 8, 6
4096x2160	2048x2160	52.515	23.957	142.000	(*2)		112, 216, 328	3, 10, 19
		52.423	23.992	115.750	(*2)		48, 32, 80	3, 10, 12
		54.000	24.000	148.500	-		510, 44, 148	8, 10, 72
		112.500	50.000	297.000	-		484, 44, 64	8, 10, 72
		133.265	59.975	294.250	(*2)		48, 32, 80	3, 10, 49
		133.320	60.000	283.704	(*2)		8, 32, 40	48, 8, 6
		135.000	60.000	297.000			44, 44, 64	8, 10, 72
3200x2400(*5)	1600x2400	148.011	59.948	260.500	-	(*4)	48, 32, 80	3, 10, 56
3840x2400(*5)	1920x2400	148.140	60.000	296.280	(*2)		8, 32, 40	55, 8, 6

*1: Indicates multi input mode settings that allow image signal to be used

*2: Since EDID is not supported, the setting has no effect (standard recommended).

*3: Only when the "Panel drive mode" is set to "4096x2160"

*4: Only when the "Panel drive mode" is set to "4096x2400"

*5: In the case of an image signal whose vertical resolution exceeds 2160, if the panel drive mode is set to "4096x2160", it will be processed as "no signal." Therefore, set the mode to "4096x2400."

About blanking information

The following figure shows the structure of the blanking period that is inserted between image signal frames.

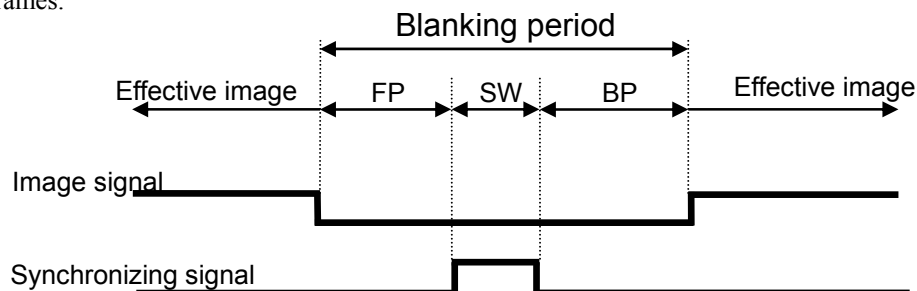

FP: front porch, SW: synchronizing width, BP: back porch

3-4 HDMI deep color (RGB444 and YCbCr444) compatibility table

Resolution (single terminal)	Frequency			8bit support	10bit support	12bit support
	Horizontal [kHz]	Vertical [Hz]	Dot clock [MHz]			
640x480	31.469	59.940	25.175			
720x480	31.469	59.940	27.000			
720x576	31.250	50.000	27.000			
1280x720	18.000	24.000	59.400			
	37.500	50.000	74.250			
	45.000	60.000	74.250			
1920x1080(I)	28.125	50.000	74.250			
	31.250	50.000	72.000			
	33.750	60.000	74.250			
1920x1080	27.000	24.000	74.250			
	56.250	50.000	148.500			
	67.500	60.000	148.500			
2560x1080	26.400	24.000	99.000			
	56.250	50.000	185.625		-	-
	66.000	60.000	198.000		-	-
3840x2160	54.000	24.000	297.000		-	-
	56.250	25.000	297.000		-	-
	67.500	30.000	297.000		-	-
4096x2160	54.000	24.000	297.000		-	-

3-5 Internal functions

HDCP

This product is an HDCP version 1.4-compliant image device.

The digital image signals for HDCP contents that are encrypted and sent from digital devices connected to the HDMI terminal and DVI terminal can be displayed.

HDCP is an “encryption system for digital video signals.”
It AISYS a TMDS link with DVI or HDMI terminals.

HDCP transmitter is built in the signal server and HDCP receiver is built in the signal receiver.
This system can make the signals code, transmit, decode and display.

1. The transmitter authenticates the receiver: If the authentication fails, signals are not transmitted. Immediately after authentication, a key (the encryption rule) is shared: The key is updated every two seconds.
2. The transmitter encrypts the information with the key and sends the encrypted (digital) signal. If the key update does not match, the transmissions stop.
3. The receiver receives the encrypted signal, decodes the signal with the key, and displays the signal on the display device.

Frame lock function

Depending on the input signal’s frequency, commonly-used display devices may not be able to synchronize the input signal’s frame with LCD’s frame, thereby showing a mixture of successive 2 frames.

The following illustrates how this mixture of frames (image shift) occurs. Numbers to indicates the order in which these images appeared.

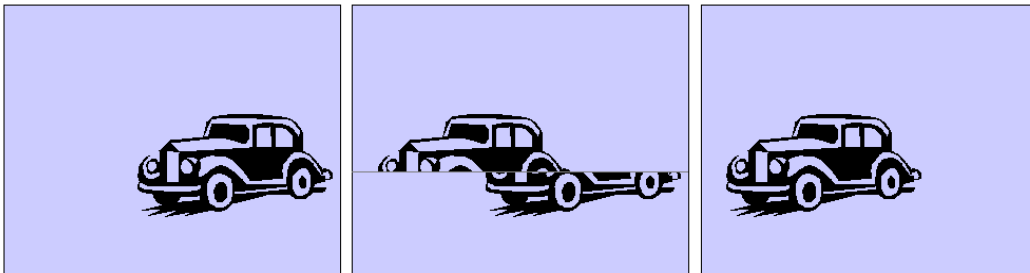

In this example, a composite image appeared when an object moved from right to left, which is a combination of the frames before and after the movement.

This function synchronizes the LCD’s frame with that of input signal to prevent this kind of frame mixture, and it is effective for input signals of about 23 to 31 Hz and about 47 to 61 Hz.

For frequencies other than these ranges, a different process takes effect in place of Frame Lock (synchronization) to ensure that a single frame appears in the entire LCD. Therefore, composite image like would not appear even in those cases.

In the past, asynchronous methods were adequate for inputs from computers because they mainly consisted of still images so no image overlapping could be seen. When moving images are played back, however, image-overlapping takes place because of a slight difference between the image signal and the LCOS-panel drive frequency. As more moving images are played back from computers these days, the frame lock function is used to synchronize computer inputs to counteract this problem, resulting in smooth image playback.

5. States of this product

4-1 States

This product is in one of six states.

State (*1)	Outline
No Power	No power is being supplied from outside. The projector does not operate at all.
Off (Standby)	Power is being supplied from outside. However, the circuit is only partially live and the projector itself is not active. Depending on the Network function setting, this status can be categorized into 3 modes.
Projection (On)	A status where the projector is used normally. Power is being supplied to the entire circuit. The lamp is lit, and image is projected.
Lamp Off	Power is supplied to the entire circuit except panel circuit. The lamp is unlit and the cooling fan is operating. Some action changes the projector to the projection state. However, the lamp on time is the same as actual activation.
Error	Power is being from outside but the projector cannot be activated. To use the projector, action should be taken according to the contents of the error type.
Pre-warning High temperature	If the temperature becomes almost abnormal, the projector displays the warning of high temperature. This state is cleared when the temperature goes down.
Pre-warning Lamp replacement	If the lamp replacement conditions are almost satisfied, the projector displays the warning of the lamp replacement. This state is cleared when the lamp counter for replacement is reset.

4-2 Type of Error

Each error state is defined as below.

Error name	Outline
Temperature abnormality	<ul style="list-style-type: none"> • The internal temperature is abnormally high. • The outside air temperature is higher than specified. • Malfunction of thermal sensor
Faulty lamp	<ul style="list-style-type: none"> • The lamp is out of life. • The lamp drive circuit is faulty.
Faulty lamp cover	<ul style="list-style-type: none"> • The lamp cover is not closed.
Faulty air filter unit	<ul style="list-style-type: none"> • No air filter is attached.
Faulty cooling fan	<ul style="list-style-type: none"> • The cooling fan does not operate normally.
Faulty power supply	<ul style="list-style-type: none"> • The supply voltage is abnormal. • Other abnormal is occurred.
Faulty lens shift connector	<ul style="list-style-type: none"> • Lens shift connector is not connected (It is necessary to detect the lens shift position)

** Each error state may be caused by a fault other than the above.

5. Accessories

5-1 Main Supplied Accessories	Remote Control RS-RC05	Power supply: DC 3.0V (with two AA battery) Communication range: approx. 8 m within ± 25 degrees of the receiver Allows for wireline connection (*1)
	Power code	Connects the unit to a power source.
5-2 Optional Parts	Ceiling Attachment RS-CL15 (*2)	This is used for ceiling mount. (*1)
	Ceiling Pipe 400-600mm RS-CL08	The RS-CL08 is used in combination with the RS-CL15 to suspend the projector at a distance below the ceiling.
	Ceiling Pipe 600-1000mm RS-CL09	The RS-CL09 is used in combination with the RS-CL15 to suspend the projector at a distance below the ceiling.
	Remote Control RS-RC04	Power supply: DC 3.0V (with two AAA battery) Communication range: approx. 8 m within ± 25 degrees of the receiver
	Remote Control RS-RC05	Same as the supplied remote.
5-3 Replacement Parts	Lamp Assembly with Replacement Air Filter RS-LP10F	RS-LP10 Super High Pressure Lamp for projectors Recommended lamp replacement time (*3) 400 W: 3000H, 300 W: 4000H RS-FL03 Replacement air filter
	Replacement air filter RS-FL03	This filter is installed at the air intake to prevent dust from entering.

*1: Uses a commercially available audio cable (3.5 Φ stereo mini-plug) for cable connection.

*2: Do not attach a different model's attachment. The size and the weight of a product are different from other modes.
Consult a building professional before attempting to mount the projector to a ceiling.

*3: This time guarantees a 50% survival rate and a 50% brightness-maintenance rate.

This value does not guarantee the service life of the lamp.

6. Product Appearance

6-1 Outline Drawings

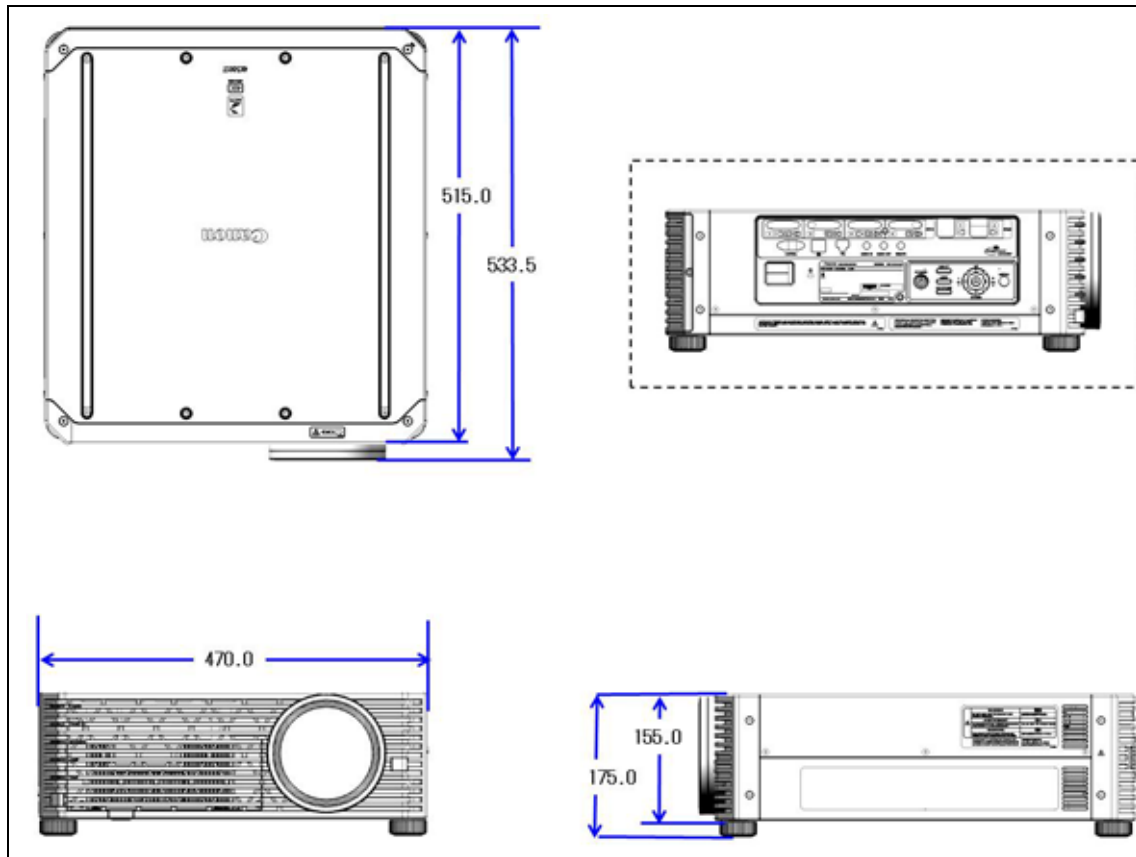

Dimensions:

W: 470.0 mm, H: 175.0 mm, D: 533.5 mm (18.5 x 6.9 x 21.1 inch) * including protrusion

W: 470.0 mm, H: 155.0 mm, D: 515.0 mm (18.5 x 6.1 x 20.3 inch) * not including protrusion

Lens center: 122.0 mm from the left side ("front" is the side where lens is attached.)

100.0 mm from the installed surface

Screw holes for ceiling mount: 4 (M6)

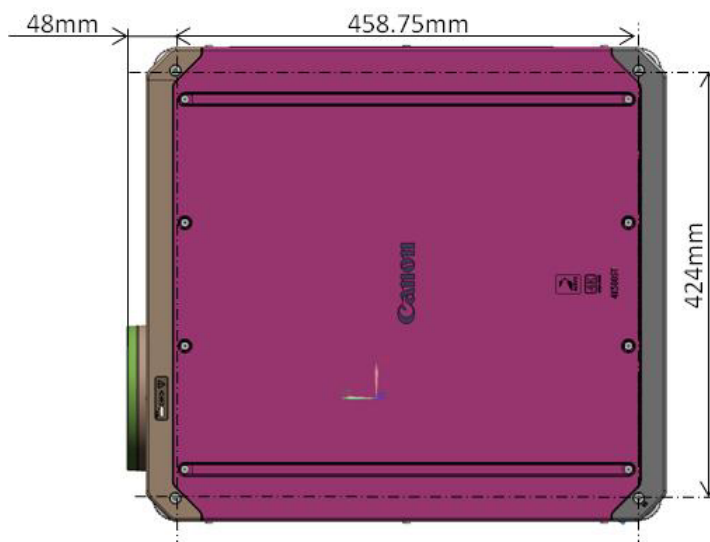

Canon

6-2 Part Names

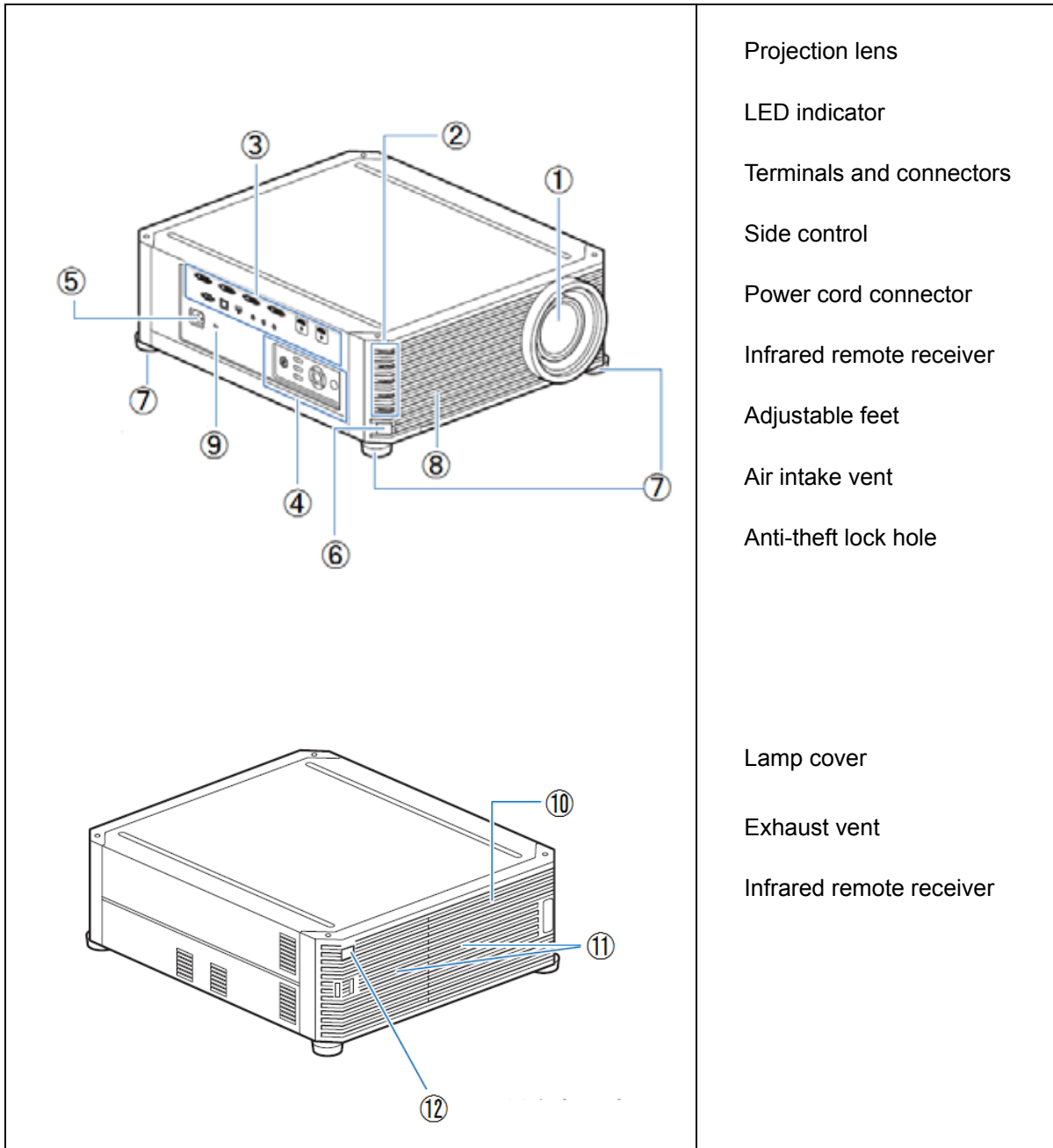

6-3 Terminals

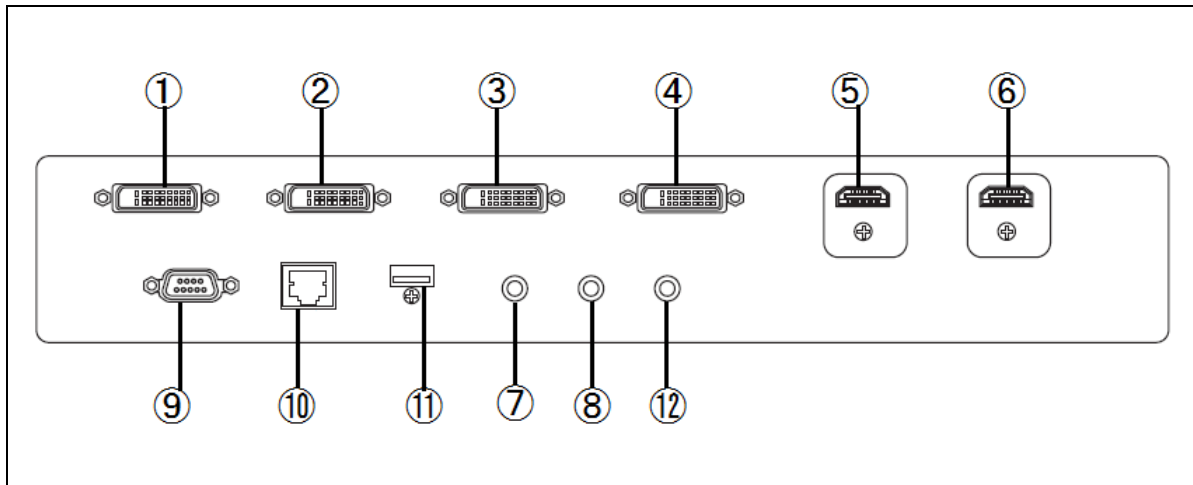

Type	Terminal	Signal
Image input	DVI-D (1)	Digital PC
	DVI-D (2)	Digital PC
	DVI-D (3)	Digital PC
	DVI-D (4)	Digital PC
	HDMI (1)	Digital PC/Digital video
	HDMI (2)	Digital PC/Digital video
Audio input	Mini jack	Stereo audio
Audio output	Mini jack	Stereo audio
Control	Dsub9	RS-232C connection
	RJ-45	1000BASE-T/100BASE-TX/10BASE-T
	USB type A	USB connection
	Mini jack	Wired remote control connection

Wireline connection for the remote

The unit can be operated by a wired remote RS-RC05 (option).

When a cable is connected to the unit's remote terminal, the unit switches to a mode in which no infrared signal is accepted, so that the unit would not respond to other remote.

In addition, when a cable is connected to the wireline connection terminal on the remote, the remote also switches to a mode in which no infrared signal is transmitted.

When the remote is wired, the user does not have to make the channel settings on the unit or the remote.

**Note:

If the cable connecting the unit and the remote breaks, the unit will become inoperable from any remote.

6-4 Indicators and Control buttons

Illuminate to indicate the projector state.

POWER ON	POWER ON (Green)	Lit	Projection state
		Blinking	Initializing (Off → Projection)
		Off	Other than above
STAND BY	STAND BY (Red)	Lit	Off state
		Blinking	Shutting down (Projection → Off)
		Off	Other than above
WARNING	WARNING (Red)	Lit	Error state
		Blinking	Error state
		Off	No error state
LAMP	LAMP (Orange)	Lit	Lamp error (*1), Lamp cover error (*2)
		Blinking	When the lamp replacement period approaches
		Off	Other than above
TEMP	TEMP (Red)	Lit	Temperature error
		Blinking	When a temperature error condition is imminent
		Off	Other than above

By the combination of indicator states, various other states are indicated.
For details, refer to the user's manual.

*1: [Warning] lights together.

*2: [Warning] blinks together.

Control the projector by button operation.

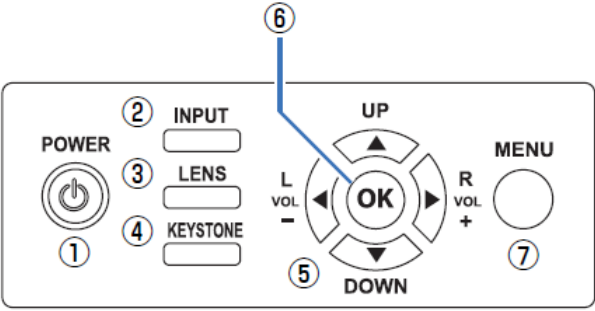
	
POWER	Turns the power supply on or off.
INPUT	Displays a select screen of input signal for projection.
LENS	Changes the display to the focus, marginal focus (when activated), zoom, or lens shift adjustment screen each time the button is pressed.
KEystone	Displays the adjustment screen of H-V keystone or Corner adjustment
Direction / VOL	Adjust the volume. (Right and left only) Move the pointer vertically or horizontally on a menu screen or other
OK	Confirms a state selected on a menu screen or other.
MENU	Displays a menu screen.

6-5 Remote Control

The supplied remote RS-RC05 can be used either through wired or wireless (infrared signal) connection.



●本体と同じ操作

[POWER]	Power (On/Off)
[INPUT]	Changing of input signal
[KEystone]	H-V keystone/Corner adjustment
[MENU]	Menu
[←] [→] [↑] [↓]	Direction (Moving)
[VOL (+ -)]	Volume adjustment
[OK]	OK

●本体ではメニュー画面から行う操作

[ASPECT]	Aspect selection
[TEST PATTERN]	Test pattern
[IMAGE]	Image mode selection

●リモコンだけの操作

[DIGITAL]	Changing of DVI input
[HDMI]	Changing of HDMI input
[EXIT]	Clears a temporary condition Closes menu screen
[FOCUS]	Focus/Marginal focus
[ZOOM]	Zoom adjustment
[SHIFT]	Lens shift adjustment
[FREEZE]	Freeze
[BLANK]	Blank
[MUTE]	Mute
[1] ~ [9]	Input numbers
[Ch]	Channel setting of remote

●不使用

[AUTO PC]	(for analog PC input)
[ANALOG]	(Unavailable function)
[COMPONENT]	(Unused signal)
[D.ZOOM]	(Unavailable function)
[Fn]	(Unavailable function)

Channel settings on the remote

Ch1	Press and hold [Ch] and [1] buttons for 3 seconds at the same time
Ch2	Press and hold [Ch] and [2] buttons for 3 seconds at the same time
Ch3	Press and hold [Ch] and [3] buttons for 3 seconds at the same time
Ch4	Press and hold [Ch] and [4] buttons for 3 seconds at the same time
Independent	Press and hold [Ch] and [0] buttons for 3 seconds at the same time

A remote set to "Independent" can control any projector ignoring the projectors' channel settings.

7. Precautions For Use

Do not look into the projection lens while it is projecting.

The projector emits very bright light, which may damage your vision.

Do not place objects in front of the lens while projecting.

Objects may heat up and burn if exposed to the concentrated light of the projector for long periods.

Do not block the vent (intake air & exhaust) while the projector is running.

Allowing heat to build up inside the unit may lead to malfunctions or risk of fire.

Replace the lamp as soon as possible if the lamp burns out or if the replacement time is reached.

The projector uses a high-pressure mercury lamp as its light source. This lamp degrades over time and becomes dimmer as it is used. Furthermore, the possibility of the lamp bursting as it is used is extremely high. If the lamp should burst, return the projector to your local service center to have the lamp replaced and the unit inspected.

**There is a less than half probability of the lamp bursting before the lamp replacement time is reached. Normally it is most likely that the lamp will not burst before the replacement time. Even if the lamp does burst, the number of hours the lamp can be used before that happens varies depending on each lamp. Although extremely minute flaws that may occur during production have been suspected as the cause of the individual differences in the hours of use before a lamp bursts, there is no way to predict this period with accuracy.

In highlands(*1) with low atmospheric pressure, use with the following setting(*2)

To prevent internal overheat, set the Fan mode function "High-Altitude".

*1: 2300m or more above sea level